

ISB02 INLINE FUEL STRAINER CHASSIS BUILD SEPTEMBER 02

Every Cummins ISB02 RV that FCCC has built since September 2002, has an in-line Fuel Strainer from the factory.

This is NOT a Fuel Filter but rather a **104 Micron Strainer**. If you look in Parts Pro for Fuel Filter it will not show up because it is a **Strainer**. It is in MOD 216 with the Fuel Lines Listed as a
{ Part Number, RAI 025RAC10 FUEL STRAINER,1/2NPT }.

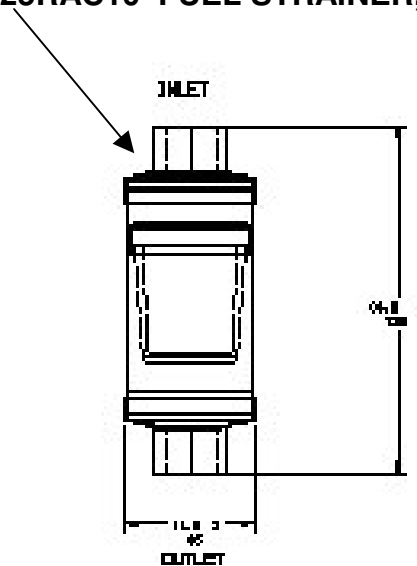

This Strainer should be changed if a lack of power is noticed, along with the Fuel Filter and or the Fuel Water Separator. If NO lack of power is noticed then **the Strainer should be changed every time the Fuel Water Separator is changed or when any Fuel filter is changed.**

Replacing Inline Fuel Strainer Cummins ISB02 Engine

Note: Vehicles with a Cummins ISB02 engine have an inline fuel strainer located inside the rail on the right-hand side above the rear axle.

1. Remove the brackets on each end of the fuel strainer.
2. Remove the P-clip

IMPORANT: The **Fuel Flow Arrow** on the fuel strainer must be **pointed toward the rear** of the vehicle.

3. Remove the strainer, and replace it with a new strainer
4. Install the P-clip.
5. Install the brackets on each end of the fuel strainer.